

## OVERVIEW

Thanks for buying our ToneShapers Wiring Kit! With this kit you can wire your Les Paul with push/pull pots, and this will provide additional tonal flexibility compared to using standard pots.

There are many ways to configure switches, and no one document can hope to address them all. You'll find many wiring diagrams on the Internet, but there are many "gotchas" out there: You'll find incomplete pieces of information that don't consider your specific situation, and so you may find that what you initially thought was doable is in fact not doable.

So our goal here is to provide several real-world wiring schemes in their entirety, that actually work. The color-code used here is Duncan's; you may need to adjust if you're using another brand.

## TWO COIL-SPLIT CONTROLS

This scheme uses each push/pull pot to split one pickup. So pulling up the neck pickup's tone pot splits the neck pickup, and pulling the bridge pickup's tone pot splits the bridge pickup. This gives you granular control over the coil splitting, so you can have the bridge pickup as a humbucker and the neck as a single-coil (for instance), and then toggle between these settings using the pickup selector.

## TWO SERIES/PARALLEL CONTROLS

This is similar to the wiring above, but rather than actually split the pickups into single-coils, this wiring allows you to selectively combine the coils of a single humbucker in either series or parallel. Series is the default wiring for almost all humbuckers (there are exceptions), and this is part of what gives them that characteristic powerful, midrange tone that Gibsons are famous for.

But combine the two coils in parallel instead (like Fender does with Strats and Teles), and you get a more open, chimey sound, that still retains hum-cancelling. Pretty neat. It's not quite the same as having true single coils, but the *hum-cancelling* benefit will be enough to seal the deal for many players.

## DUAL COIL-SPLIT + PHASE REVERSE

This scheme uses one of the push/pulls to simultaneously split both pickups, and the other to put the two pickups out-of-phase with each other in the middle (combined) switch position. That is, the phase reversal will have no tonal consequence when using only the neck or only the bridge pickup. But when both pickups are on - whether in humbucking mode or coil-split mode - their phase will be reversed relative to each other. This will result in a hollow, scooped-mid tone that can be very useful, especially when you manipulate one of the volume controls a little.

The downside of this wiring is that you cannot selectively split the humbuckers. They're either both humbuckers, or both split.

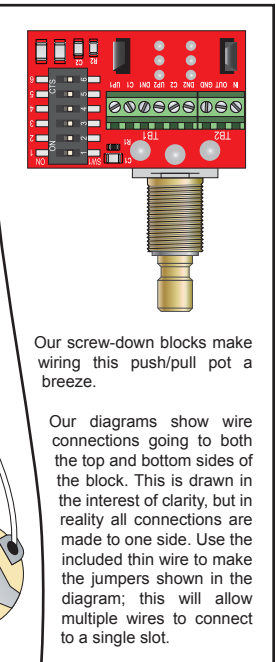
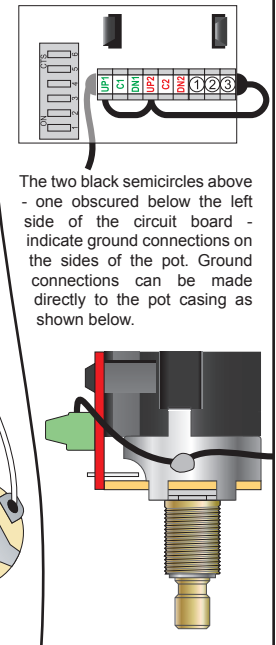
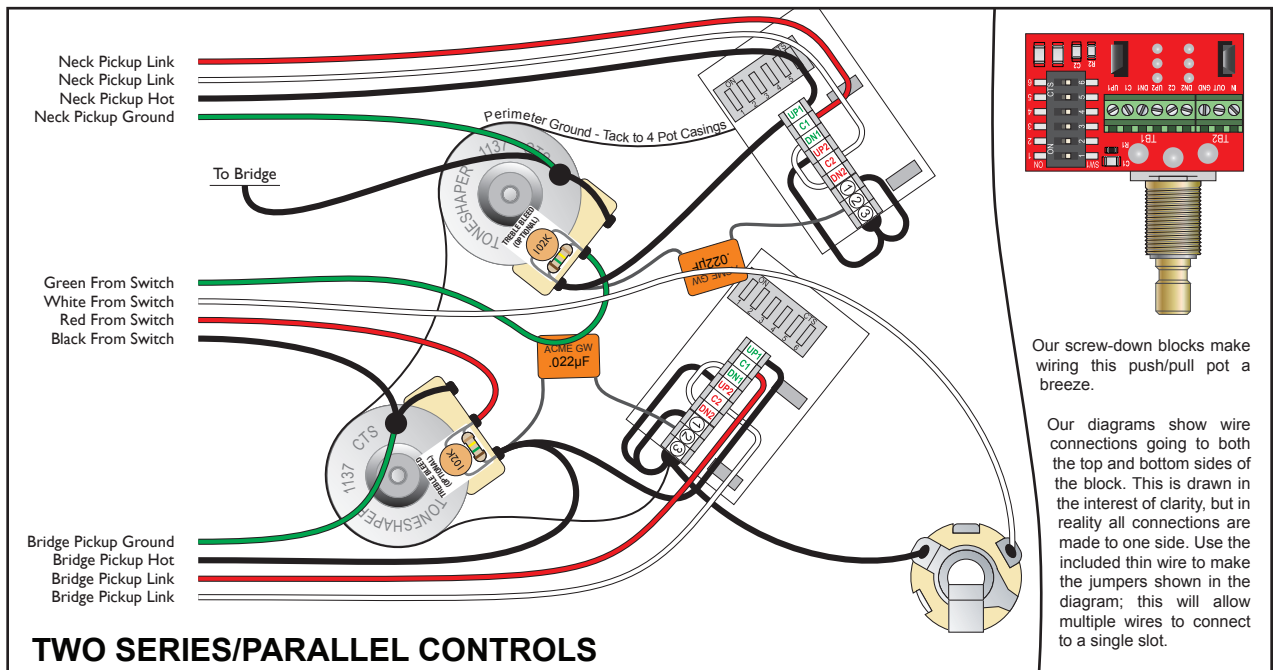
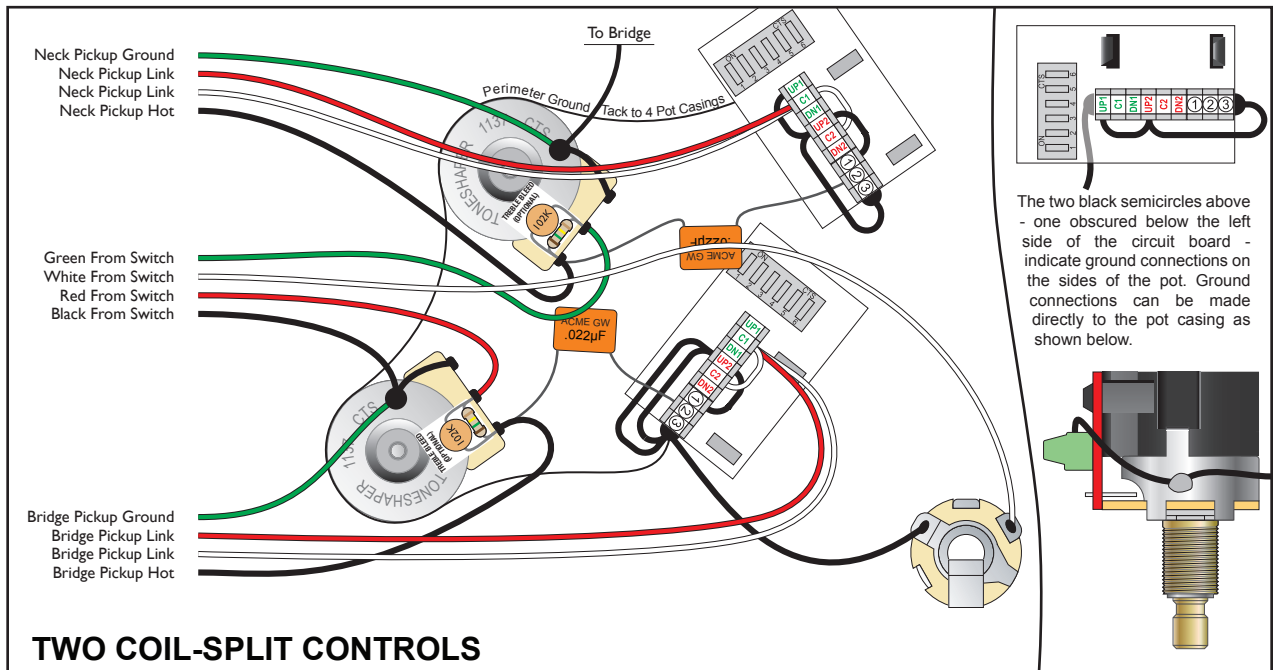

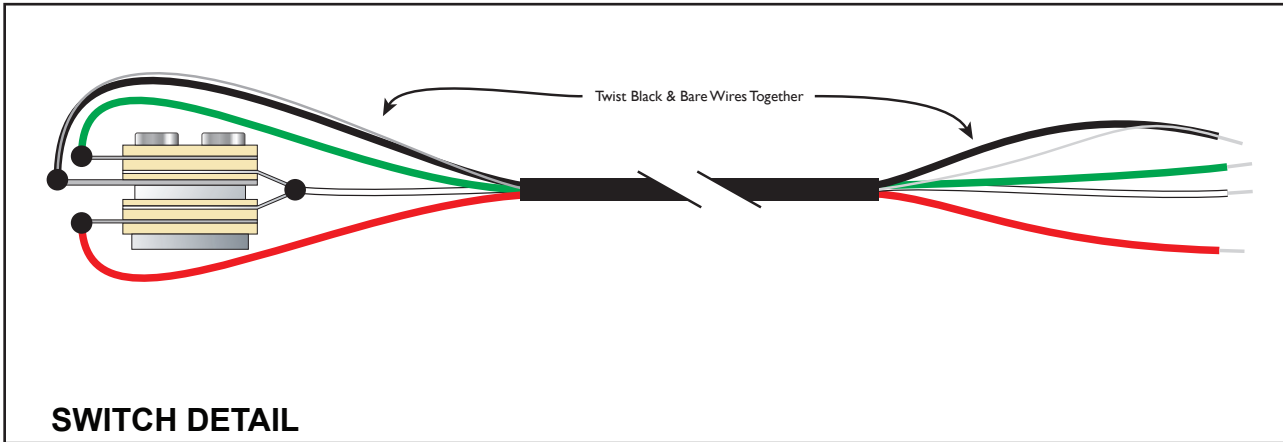

### WIRE TYPES

There are different types of wire that are commonly used to wire Gibson guitars. Gibson originally used single-conductor wire with an external braid. The braid provides shielding against EMI/RFI, so that you don't get extraneous noise in your signal from radio transmissions, transformer hum, etc.

Shielding is a good thing, but there are other ways to get it, and using braided wire is a pain. So we typically use 4-conductor wire as shown at left to connect the switch to the other components. It's much easier to use than braided wire (we think), it's also fully shielded, and there is absolutely no tonal downside (don't let anyone fool you on this point).

We generally find that players who are trying to retain *vintage correctness* will elect to use the braided wire. In any case, we give you both types of wire with our Gibson kits, and you can use whichever you want. Of course, most people who buy our kits with push/pull pots will also be using either three or four conductor pickups, so at that point *vintage* kind of goes out the window. But it's there for your switch connections if you want, just refer to the package insert for a few tips regarding the use of braided wire.

The signal chain in most Gibson guitars follows the path **pickups > volume pots > switch > jack**. The wire from the pickups to the volume pots will obviously be determined by the manufacturer of your pickups, and may be different than our diagram. You'll need to adjust accordingly. But the rest of the path (**volume pots > switch > jack**) can be completed with a single length of 4-conductor wire. The signal from the **volume pots > switch** is carried on the green/red wires, while the signal from the **switch > jack** is carried on the white wire. The black/bare wires carry ground.

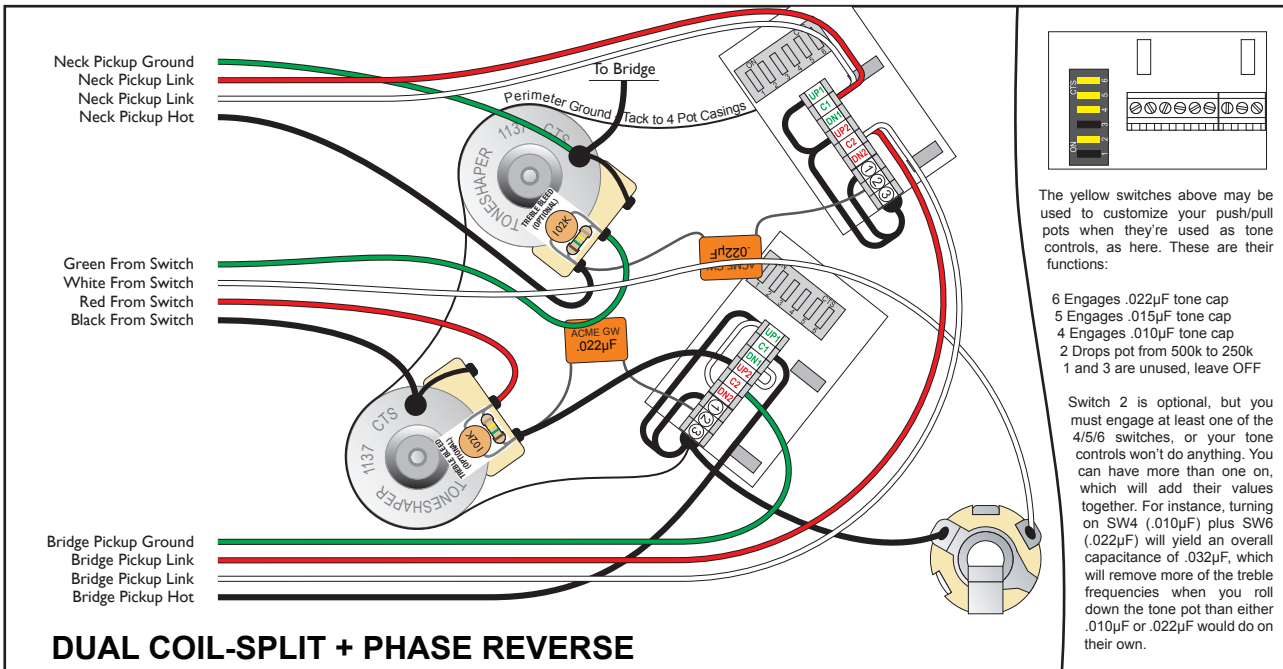

The yellow switches above may be used to customize your push/pull pots when they're used as tone controls, as here. These are their functions:

- 6 Engages .022µF tone cap
- 5 Engages .015µF tone cap
- 4 Engages .010µF tone cap
- 2 Drops pot from 500k to 250k
- 1 and 3 are unused, leave OFF

Switch 2 is optional, but you must engage at least one of the 4/5/6 switches, or your tone controls won't do anything. You can have more than one on, which will add their values together. For instance, turning on SW4 (.010µF) plus SW6 (.022µF) will yield an overall capacitance of .032µF, which will remove more of the treble frequencies when you roll down the tone pot than either .010µF or .022µF would do on their own.

### GROUNDING

You'll see that we tack ground wires to the sides of pots, we call this a *perimeter ground*. This works well so long as you don't linger with the soldering iron: Get the heat on, get the heat off, as quickly as is feasible. The CTS pots can actually take quite a bit of heat without sustaining any damage, but the push/pull pots are a little more sensitive, so be careful.

Also, there's a little leeway regarding ground connections to the sides of pots. We've drawn the circuits from the viewpoint of maximum document clarity, not ease of installation. But if you find that you have three wires that you need to attach to the side of a pot, and find it awkward to connect all of them to a single point, you can move one of them to another point on that same pot casing, or on some other pot casing. Just make sure that you have a physical connection between the four pots, the jack's ground lug, and the switch chassis.

### SWITCH ORIENTATION

Please note that it's important that the pickup selector switch be oriented as we're showing it at left, otherwise your guitar's rhythm/treble orientation will be backward.

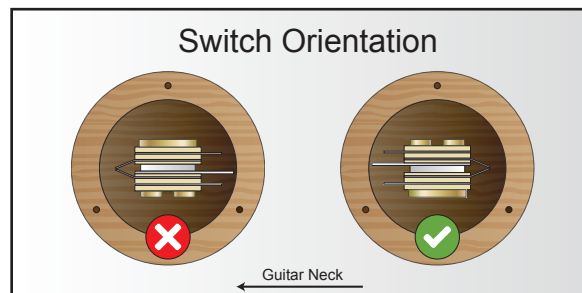



**Build A Better Guitar**  
Tone Shapers, Inc.  
772-217-8662  
www.toneshapers.com

DRAWN George Ellison	DATE 9/21/18	TITLE <b>Les Paul®</b> Modern Wiring   PP02 Push/Pull Pots (Duncan Color Codes Shown)
ASSY PN LPSTD-MPP02	ADOC	PAGE 1 of 1

© Tone Shapers, Inc. - All Rights Reserved